

Conical pick tools 采煤机镐形截齿

43 mm/35mm(1.70"/1.38") step shank 带台阶齿柄

◆JZ89/43-U170/Z25-42BN-3

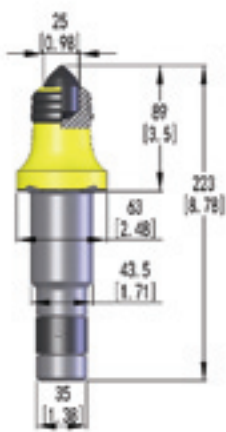

◆JZ102/43-U170/Z22-42B-3

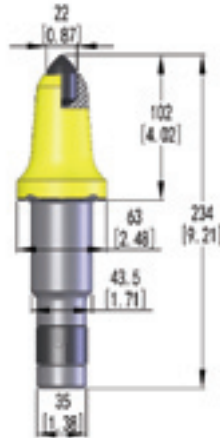

◆JZ102/43-U170/M22-42B-3

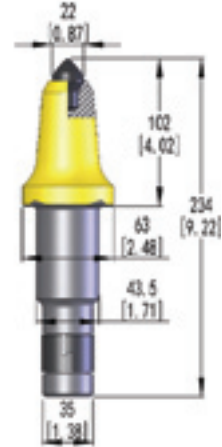

◆JZ114/43-U170/M25-42B-3

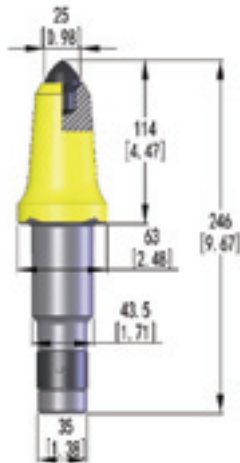

43 mm/35mm(1.70"/1.38")  
step shank



Conical pick tools 采煤机镐形截齿

35mm(1.38")shank 齿柄

◆ JZ89/35-U95/Z25-42N-3

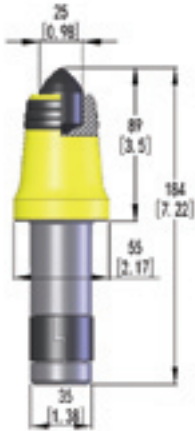

◆ JZ89/35-U95/Z25-23-3

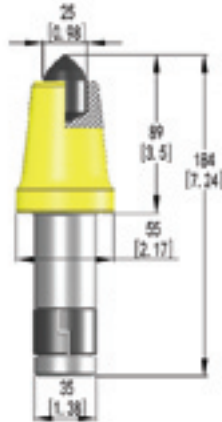

◆ JZ89/35-U95/Z22/Z4-42N-3

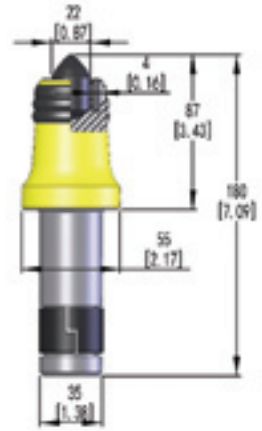

◆ JZ89/35-U94/Z19-42B-3

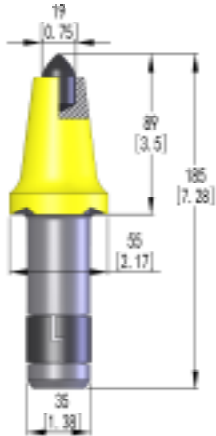

◆ JZ89/35-U94/M19-42B-3

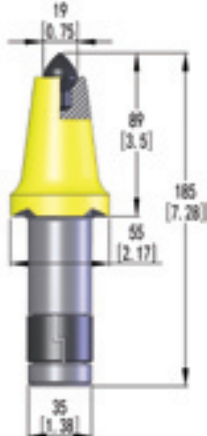

◆ JZ102/35-U92/M16-42-3

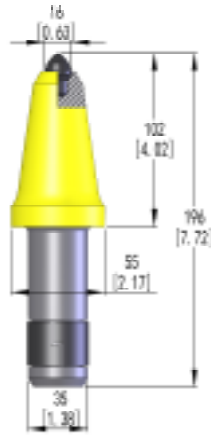

◆ JZ100/35-U92/M22-42-3

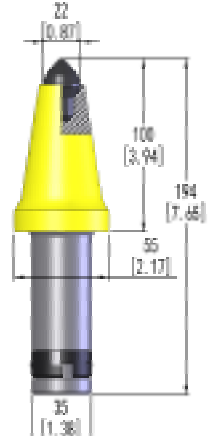

35mm(1.38")shank



Conical pick tools 采煤机镐形截齿

30mm(1.18")shank 齿柄

◆JZ70/30-U84/M19-42B-3

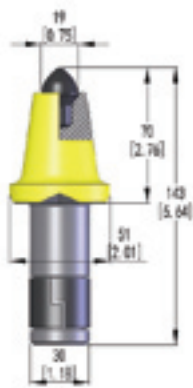

◆JZ80/30-U84/Z16-42-3

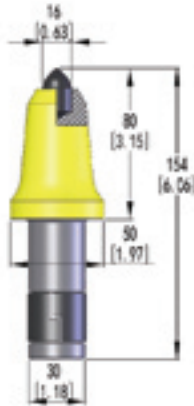

◆JZ85/30-U84/M19-42-3

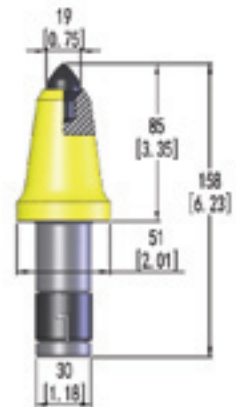

◆JZ80/30-U82/M13-42-3

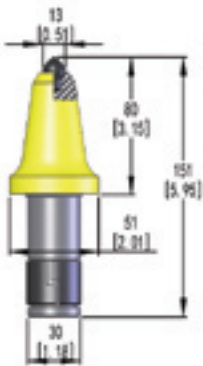

◆JZ86/30-U85/M13-42B-3

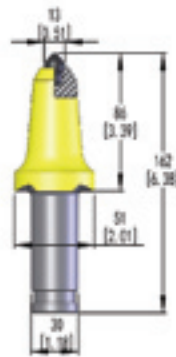

30mm(1.18")shank  
25mm(0.99")shank

25mm(0.99")shank 齿柄

◆JZ64/25-U76/Z16-42-3

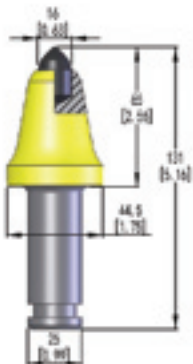

Crusher pick tools 掘进机镐形截齿

38mm/30mm(1.5"/1.18") step shank 带台阶齿柄

◆JZ70/38-U47/M19-42-3

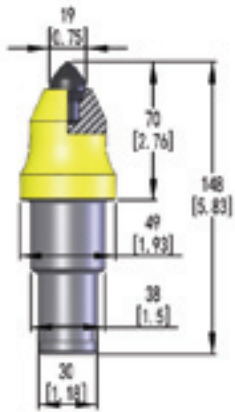

◆JZ80/38-U47/M22-42-3

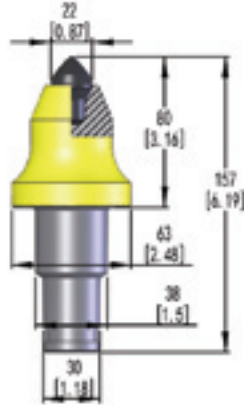

◆JZ80/38-U47/M25-42-3

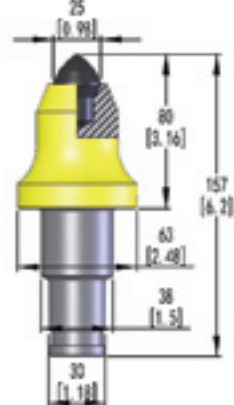

◆JZ68/38-U47/M25-42-3

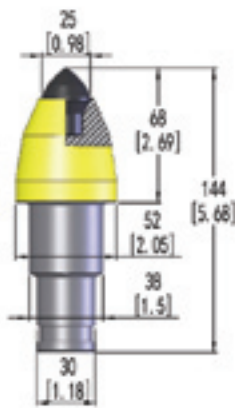

◆JZ75/38-S160/Z22-42-3

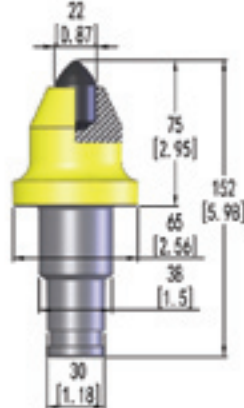

◆JZ75/38-S160/Z25-42-3

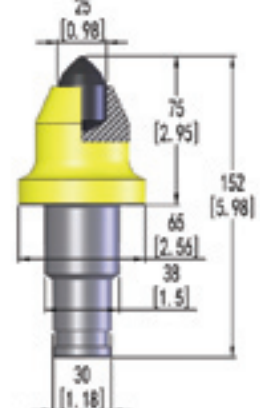

38mm/30mm(1.5"/1.18")  
step shank





**Crusher pick tools 掘进机镐形截齿**

38mm(1.5") shank 齿柄

◆ JZ80/38-U135/M22-42-3

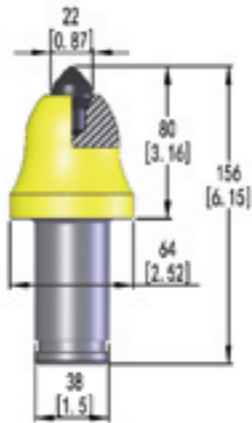

◆ JZ80/38-U135/M25-42-3

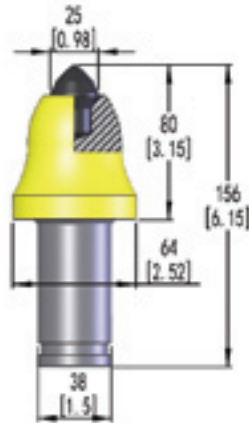

◆ JZ78/38-S150/M25-42-3

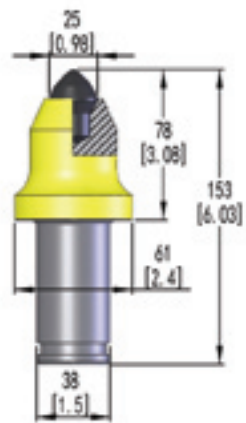

◆ JZ78/38-S150/Z25-42-3

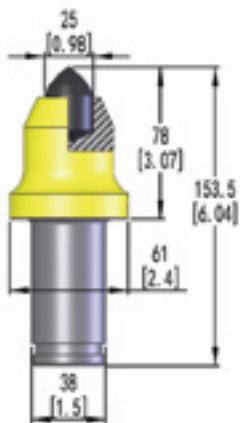

◆ JZ84/38-JMS260/M25-42-3

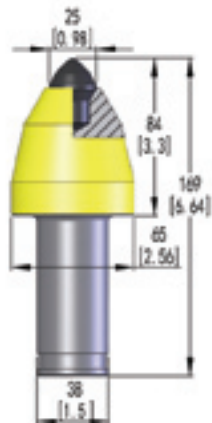

◆ JZ82/38-JMS260/Z25-42-3

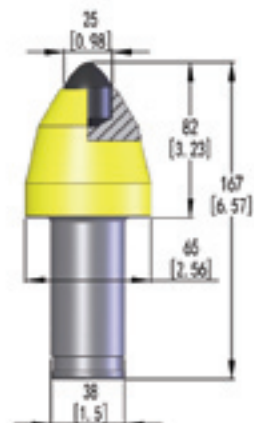

38mm(1.5") shank



Crusher pick tools 掘进机镐形截齿

34 mm(1.34") shank 齿柄

◆JZ78/34-S100/M22-42-3

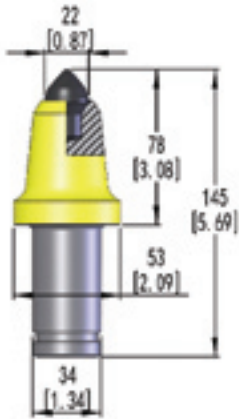

◆JZ76/34-S100/M19-42-3

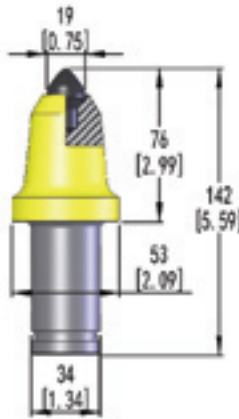

◆JZ74/34-S100/M16-42-3

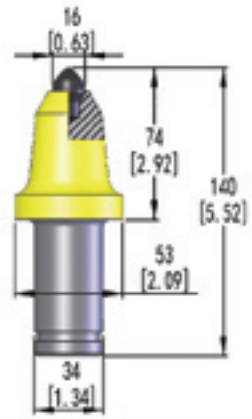

30 mm(1.18") shank 齿柄

◆JZ68/30-U120/M19-42-3

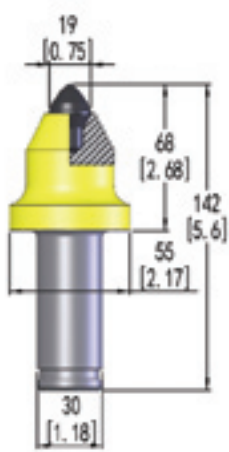

◆JZ68/30-U120/M22-42-3

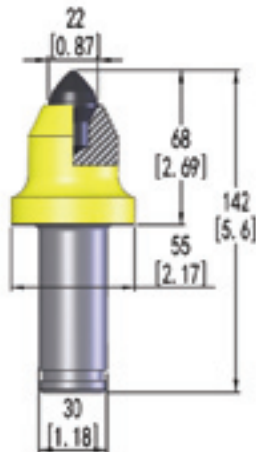

34 mm(1.34") shank  
30 mm(1.18") shank



**Flats pick tools 采煤机刀形截齿**

Flats and Radials 板齿

◆JB77/41/25-KR300-42-3

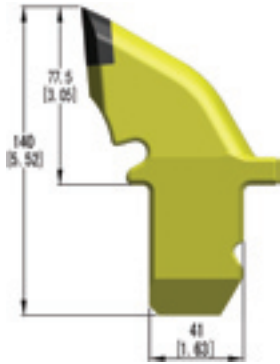

◆JB65/39/25-42-3

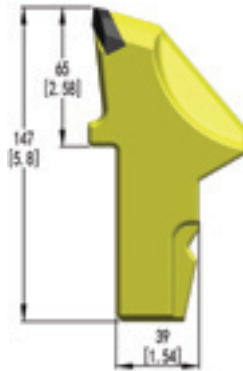

◆JB59/41/25-AM276-42-3

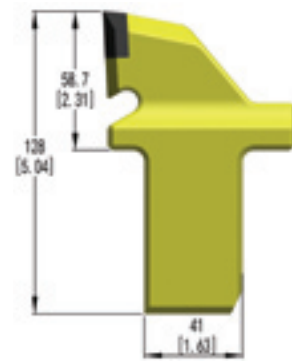

◆JB100/50/30-HDL-42-3

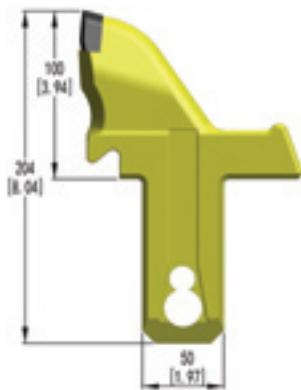

◆JB100/50/30-AUS-42-3

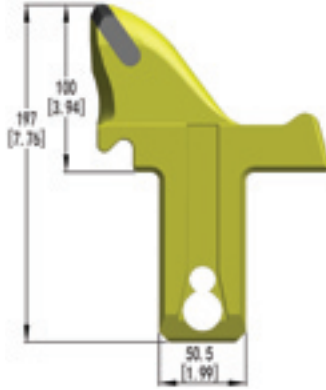

Flats and Radials



Blocks and Sleeves 齿座和齿套

Blocks and Sleeves 齿座和齿套

◆U80K177S

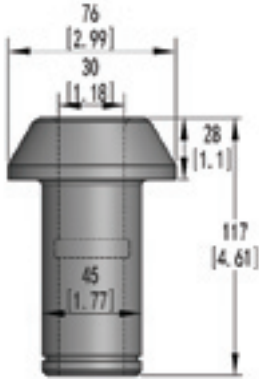

◆U90K225R

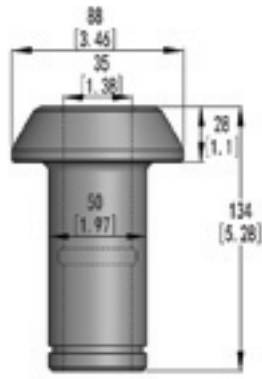

◆U170K225S

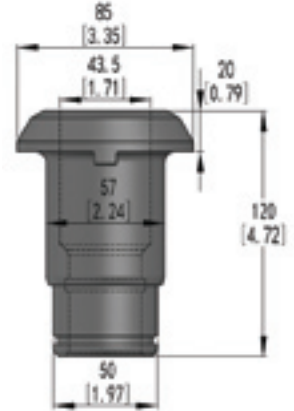

◆K225S

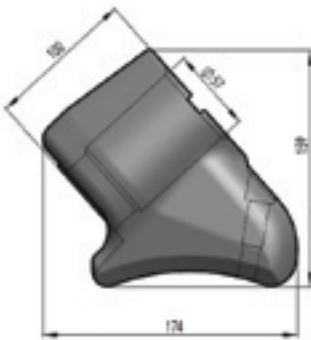

◆K177S

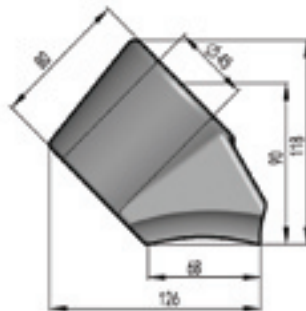

◆U43XHD



Blocks and Sleeves





Surface mining tools 表面开采

38mm/30mm(1.5"/1.18") step shank 带台阶齿柄

◆JZ89/38-TS36C/M22-23-3

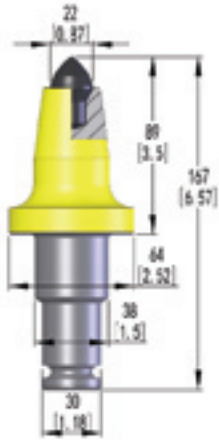

◆JZ89/38-TS37C/M25-23-3

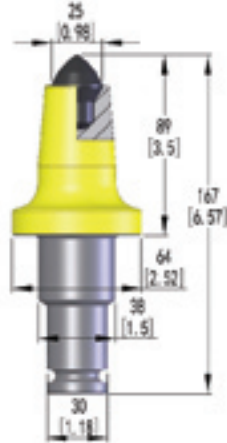

◆JZ76/38-TS30C/M25-23-3



◆JZ76/38-TS32C/M22-23-3



◆JZ64/38-TS5C/Z19-23-3

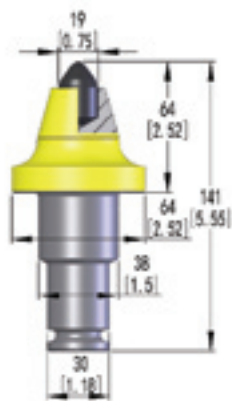

◆JZ64/38-TS40C/M19-23-3

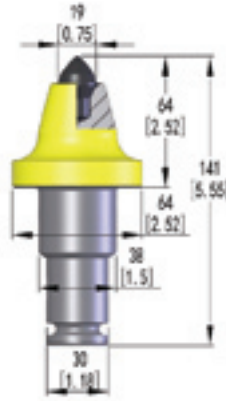

◆JZ64/38-TS41C/M22-23-3

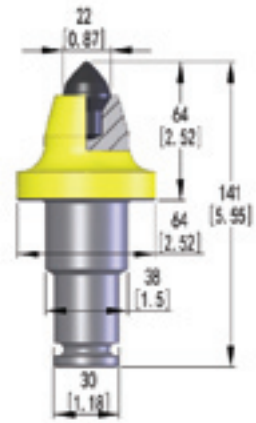

Surface mining tools  
38mm/30mm(1.5"/1.18")



## SANSHAN Mineral Ground Tools

### Surface mining tools 表面开采

38mm/30mm(1.5"/1.18") step shank 带台阶齿柄

◆ JZ77/38-WSM/Z17-23-3

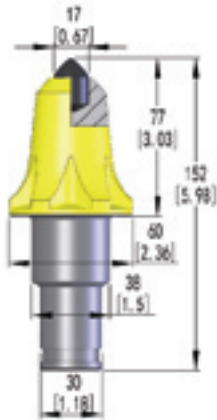

◆ JZ77/38-WSM/Z19-23-3

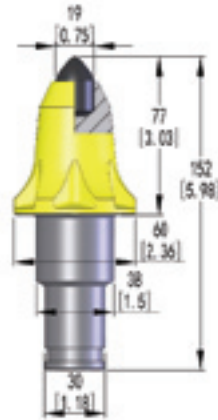

◆ JZ77/38-WSM/Z22-23-3

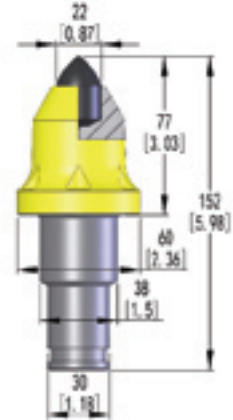

◆ JZ77/38-WSM/Z25-23-3

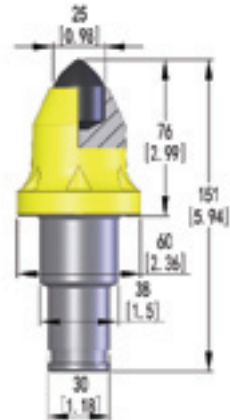

◆ JZ77/38-WSMX/Z25-23-3

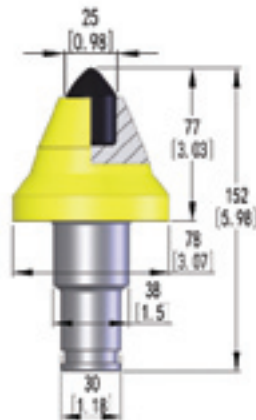

◆ JZ77/38-WSMX/Z25-42N-3

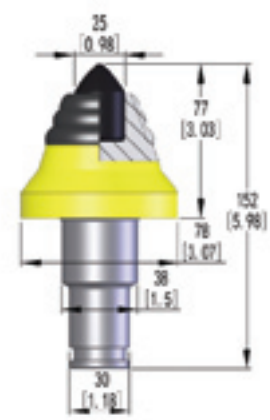

Surface mining tools  
38mm/30mm(1.5"/1.18")



Surface mining tools 表面开采

42mm (1.66") shank 齿柄

◆ JZ77/42-WSM/M22-23-3

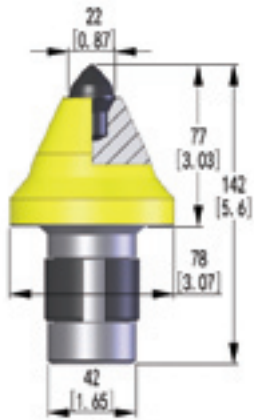

◆ JZ77/42-WSM/Z22-23-3

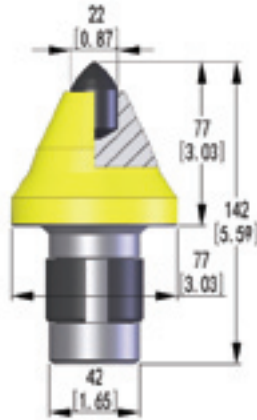

◆ JZ77/42-WSM/M25-23-3

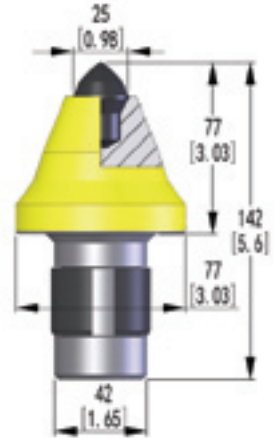

◆ JZ77/42-WSM/Z25-23-3

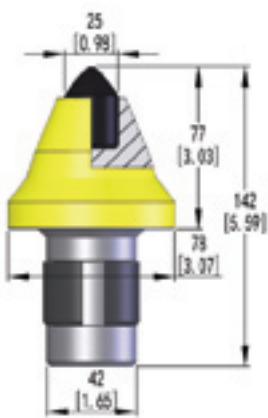

◆ JZ77/42-WSM/Z25-42N-3

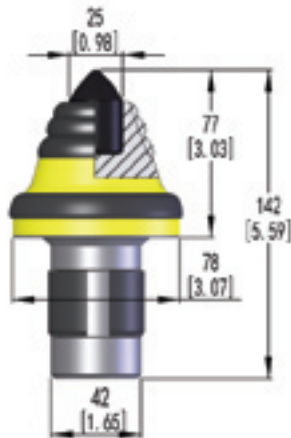

Surface mining tools  
42mm (1.66") shank



# SANSHAN Mineral Ground Tools

## Trenching tools 槽沟刀具

38mm/30mm(1.5"/1.18") step shank 带台阶齿柄

◆ JZ89/38-TS36/M22-42-3

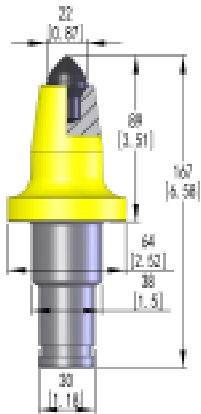

◆ JZ89/38-TS37/M25-42-3

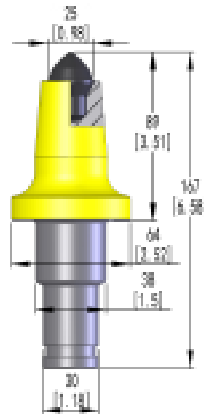

◆ JZ76/38-TS30/M25-42-3

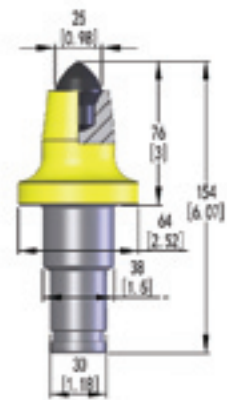

◆ JZ76/38-TS32/M22-42-3

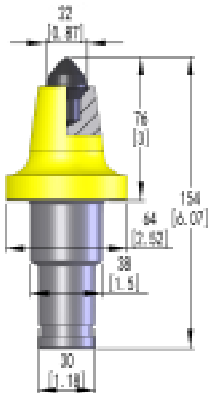

◆ JZ70/38-P3DS/Z18-42-3

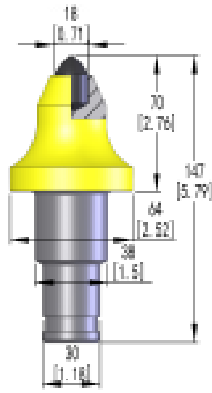

◆ JZ64/38-TS40/M19-42-3

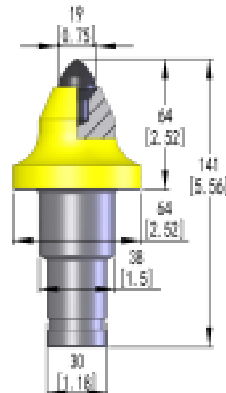

◆ JZ64/38-TS41/M22-42-3

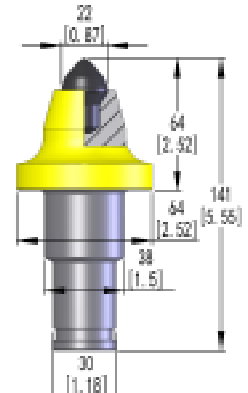

Trenching tools  
38mm/30mm(1.5"/1.18")





Trenching tools 槽沟刀具

25mm(1")shank 齿柄

◆ JZ76/25-T18/M19-42-3

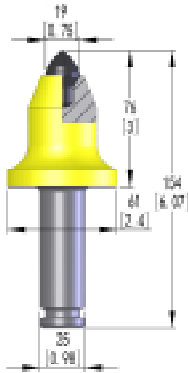

◆ JZ64/25-T19/M22-42-3

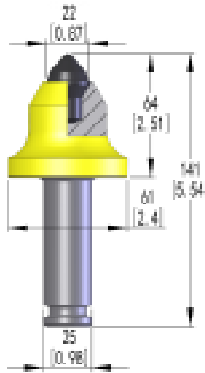

◆ JZ64/25-T20/M19-42-3

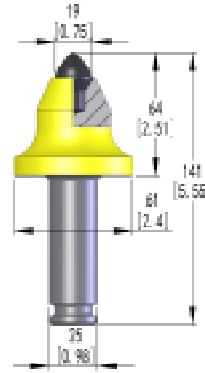

◆ JZ65/25-C35R/Z16-42-3

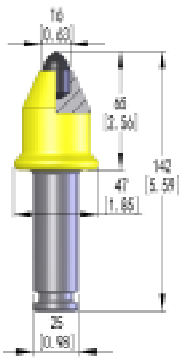

◆ Z64/25-C36R/M18-42-3

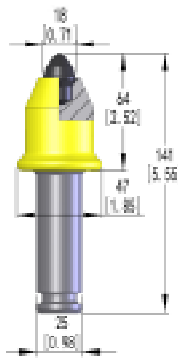

◆ JZ61/25-C31HD/Z12-42-3

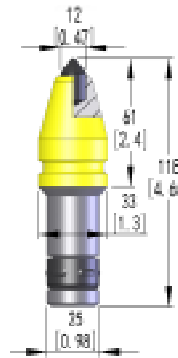

◆ JZ60/25-C34FSR/Z19-42-3

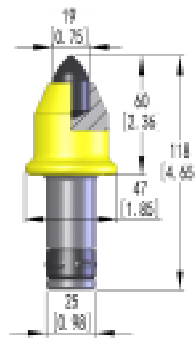

Trenching tools  
25mm(1") shank



# SANSHAN Mineral Ground Tools

## Trenching tools 槽沟刀具

22mm(.87"), 20mm(.76"), 19mm(.74"), 11mm(.44")shank 齿柄

◆JZ44/22-SM02/P16-42-3

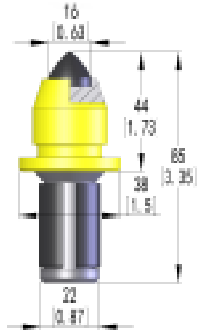

◆JZ45/22-SL04/Z12-42-3

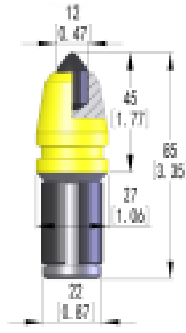

◆JZ44/20-RL10/Z12-42-3

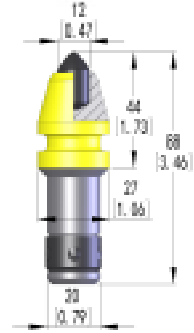

◆JZ45/20-RS17/M16-42-3

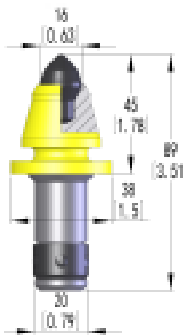

◆JZ45/19-C21HD/Z12-42-3

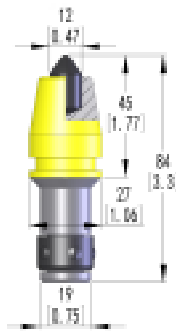

◆JZ43/19-K3LA/C16-42-3



◆JZ27/11-CM42/P16-42-3

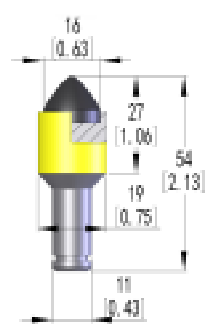

◆RT1

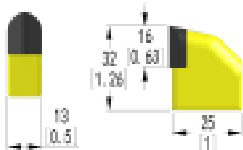

◆RT2



◆DT50



◆DT87

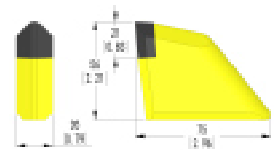

22mm(.87"), 20mm(.76"), 19mm(.74"), 11mm(.44")shank

Foundation drilling tools 打桩机钻具

38mm/30mm(1.5"/1.18") step shank 带台阶齿柄

◆ JZ70/38-DS01/Z19-42-3

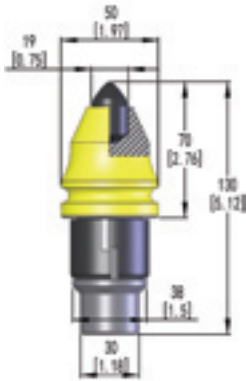

◆ JZ70/38-DS04/Z17-42-3

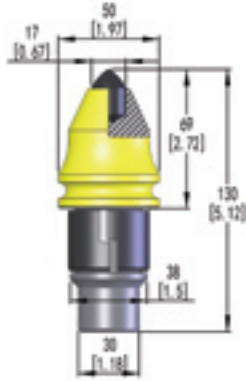

◆ JZ70/38-DS04-59/Z17-42-3

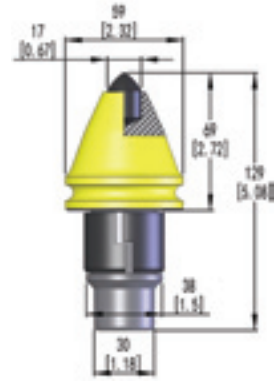

◆ JZ70/38-DS05/Z22-42-3

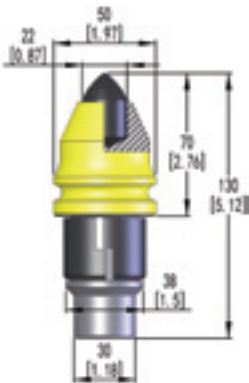

◆ JZ70/38-DS05/Z22-42N-3

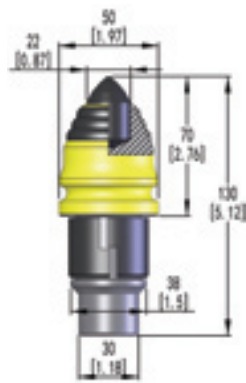

◆ JZ70/38-DS03/Z22-42-3

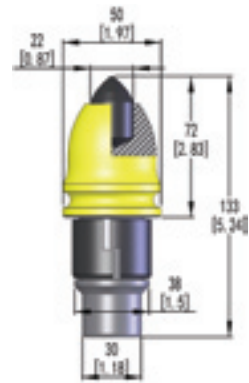

Foundation drilling tools  
38mm/30mm(1.5"/1.18")

Foundation drilling tools 打桩机钻具

Cutter teeth 旋挖齿

◆SS42L & SS38M & SS42H



◆SS65T & SS65H



◆SS70T & SS70H



◆SS80L & SS80H



◆Pilot cutter teeth 桩机中心刀

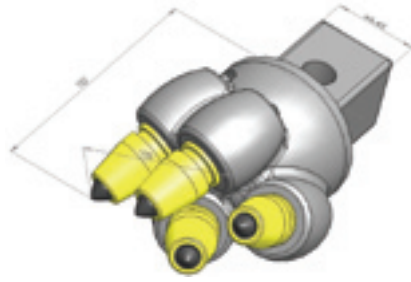

Foundation drilling tools  
Cutter teeth





**Grader blades 平地机刀头**

22mm(.87") shank 齿柄

◆JZ44/22-C858/P25-23-2

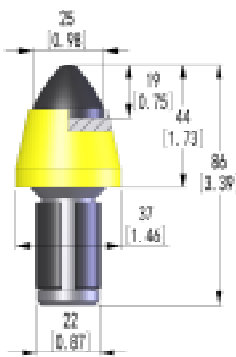

◆JZ44/22-C87/P25-23-2

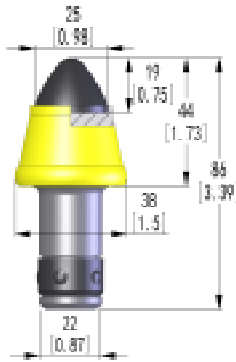

◆JZ46/22-C387/P16-23-2

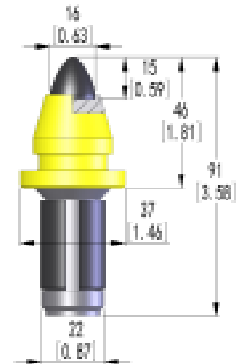

◆JZ49/22-C87/P16-23-2

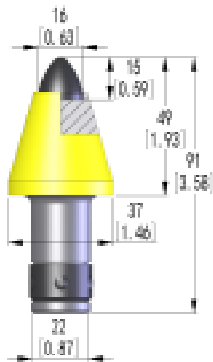

◆JZ43/22-K1LW/C16Y-23-2

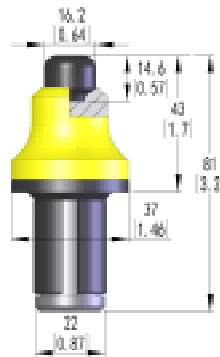

◆JZ45/22-K1LW/C16-23-2

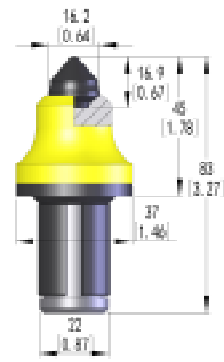

Grader blades  
22mm(.87") shank



Drilling tools for bolting 锚杆锚索支护钻头、钻杆

H19mm(0.75") drilling tools H19mm钻具

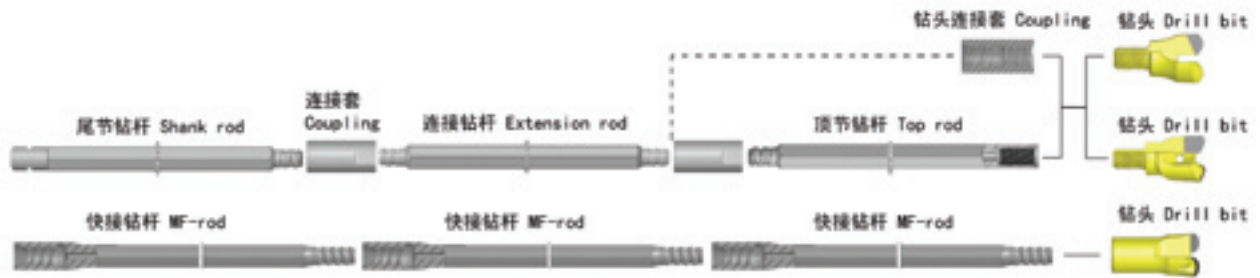

◆JZTY27/2-1/2

◆ZTY27/2-1/2

◆ZTY28/2-R16



◆ZGH19-D18.7/F14.5-L

◆ZGH19-F14.5-L

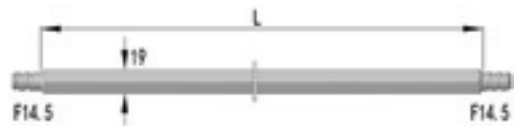

◆ZGH19-F14.5/1/2N-L

◆ZGH19-R16N/R16-L



◆LJT-F14.5N-50

◆LJT-F14.5N/1/2N-50

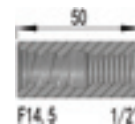
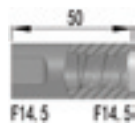

◆MGJH22-H19/H-L

◆MSJ22-H19/D-L

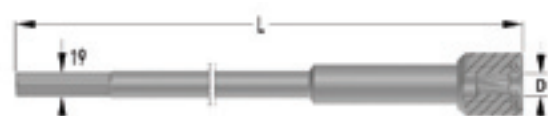
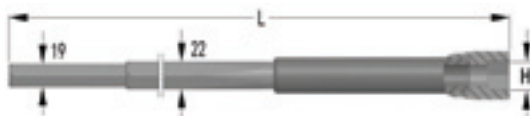

Drilling tools for bolting 锚杆锚索支护钻头、钻杆

H22mm(0.87") drilling tools H22mm钻具

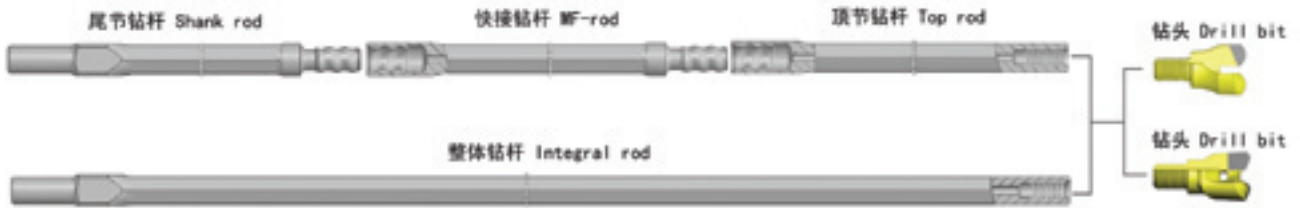

◆JZTY27/2-M14



◆ZTY27/2-M14

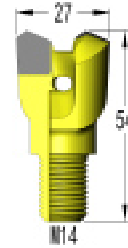

◆ZGH22-F25/R20-L



◆ZGH22-R20N/R20-L

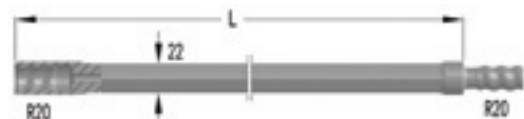

◆ZGH22-R20N/M14N-L

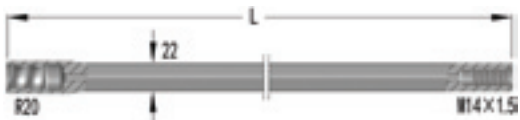

◆ZGH22-F25/M14N-L



◆MGJH22-F25/H-L



◆MSJH22-F25/D-L



H22mm(0.87")  
drilling tools

Drilling tools for bolting 锚杆锚索支护钻头、钻杆

Twist drilling tools 麻花钻具

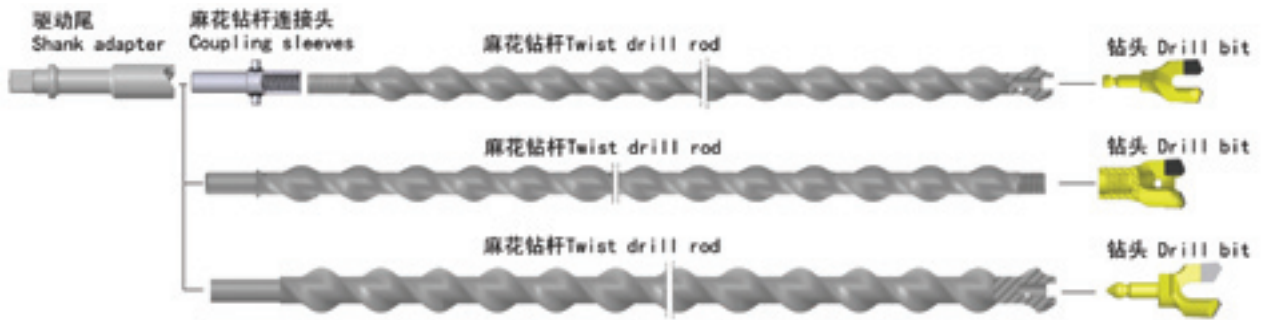

◆ZTY28/2-D8



◆ZTY30/2-1/2N



◆ZTY43/2-D12

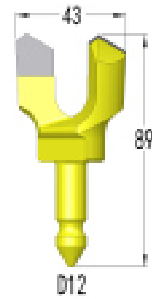

◆MHG26-M16/D8N-L

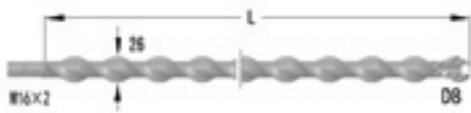

◆MHG26-D14/1/2-L

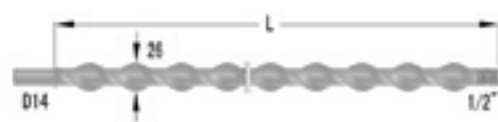

◆MHGD-D19/D12N-L

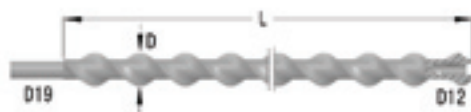

◆JT-D18/M16-110

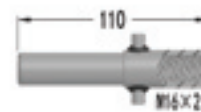



**Drilling tools for bolting** 锚杆锚索支护钻头、钻杆

F28mm powder eject in tube drilling 四方连接内排粉钻具

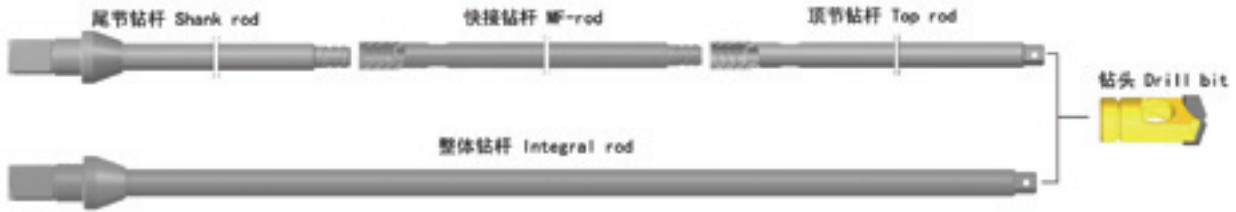

◆QNT27-H16



◆QNT30-H16



◆QNG22-F28/F18-L

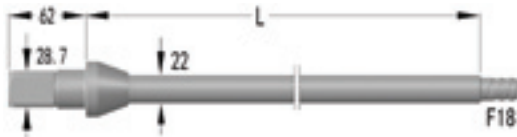

◆QNG22-F18N/F18-L



◆QNG22-F18N/H16-L

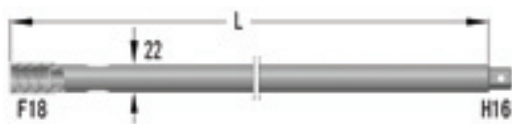

◆QNG22-F28/H16-L



◆MGJ29-F28/H-L



◆MSJ29-F28/D-L



F28mm Powder eject in tube drilling

Drilling tools for bolting 锚杆锚索支护钻头、钻杆

H28mm powder eject in tube drilling 六方连接内排粉钻具

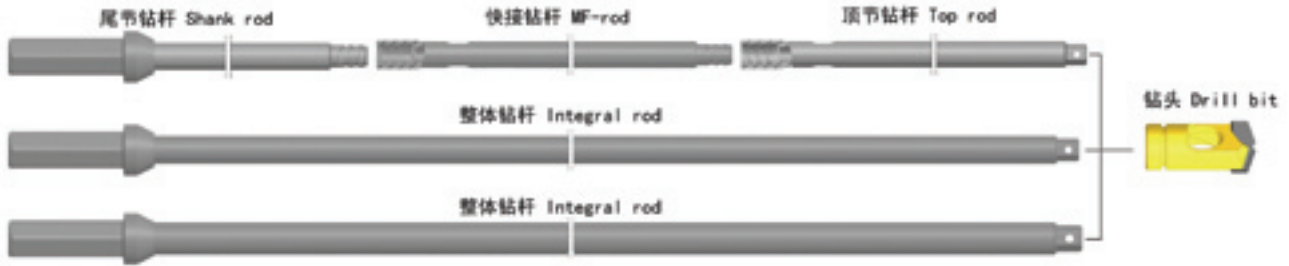

◆QNT27-H16



◆QNT30-H16



◆QNT35-H22



◆QNG22-H28/F18-L

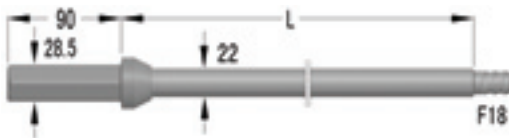

◆QNG22-F18N/F18-L

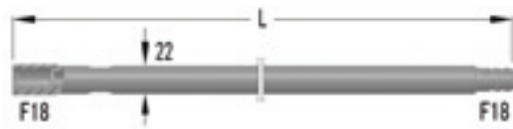

◆QNG22-F18N/H16-L

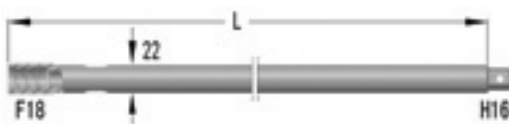

◆QNG22-H28/H16-L



◆QNG29-H28/H22-L



◆MGJ29-H28/H-L

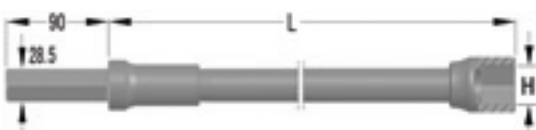

◆MSJ29-H28/D-L



Water and gas exploring drilling 探水、瓦斯钻具

Twist drilling tools 防突麻花钻具

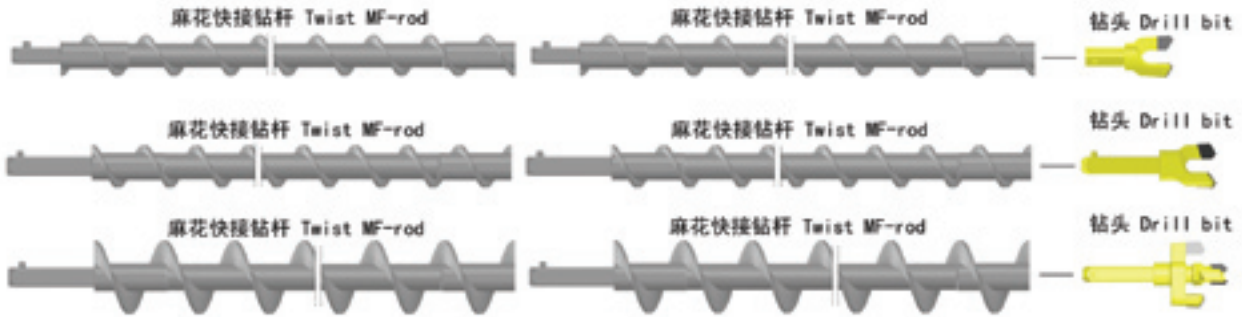

◆ZTY43/2-F14

◆ZTY46/2-F18

◆ZTY75/4-F18

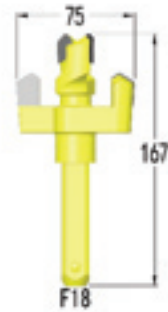

◆MHG40-F14/F14N-L

◆MHG42-F18/F18N-L



◆MHG69-F18/F18N-L



Water and gas exploring drilling 探水、瓦斯钻具

Long-hole drilling tools 深孔钻具

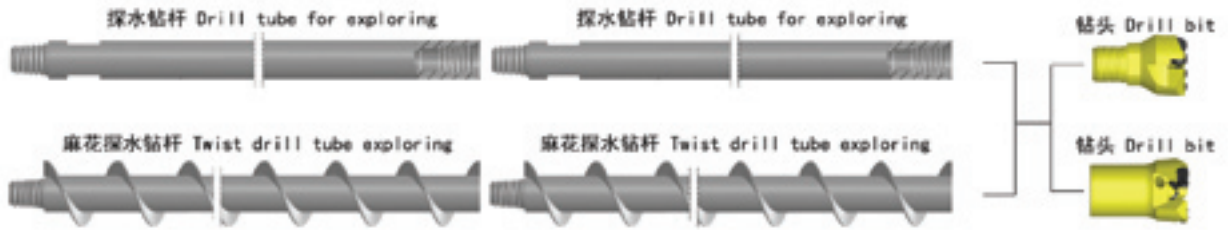

◆JZT-D/T T=Thread螺纹

◆JZT-D/T T=Thread螺纹



◆TG32-NC10-L

◆TG42-NC13-L

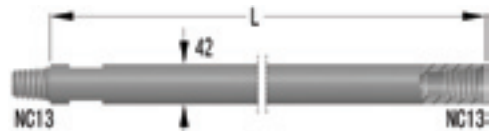

◆TG50-NC16-L

◆TG60-2 3/8"API Reg-L

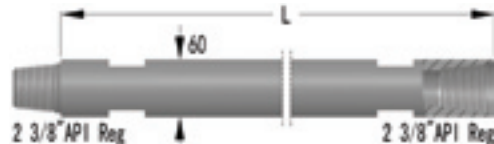
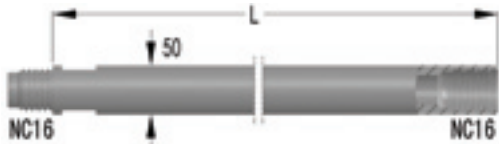

◆TMHG75-NC13-L

